

 20 min	 x1	 x1	 x1
---	---	---	---

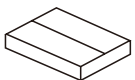

A x 2



D x 1

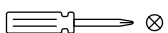
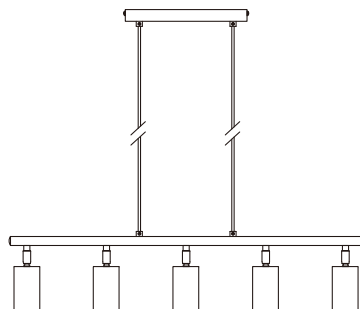

B x 1

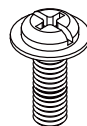

E x 2



C x 2



F x 1

OFF

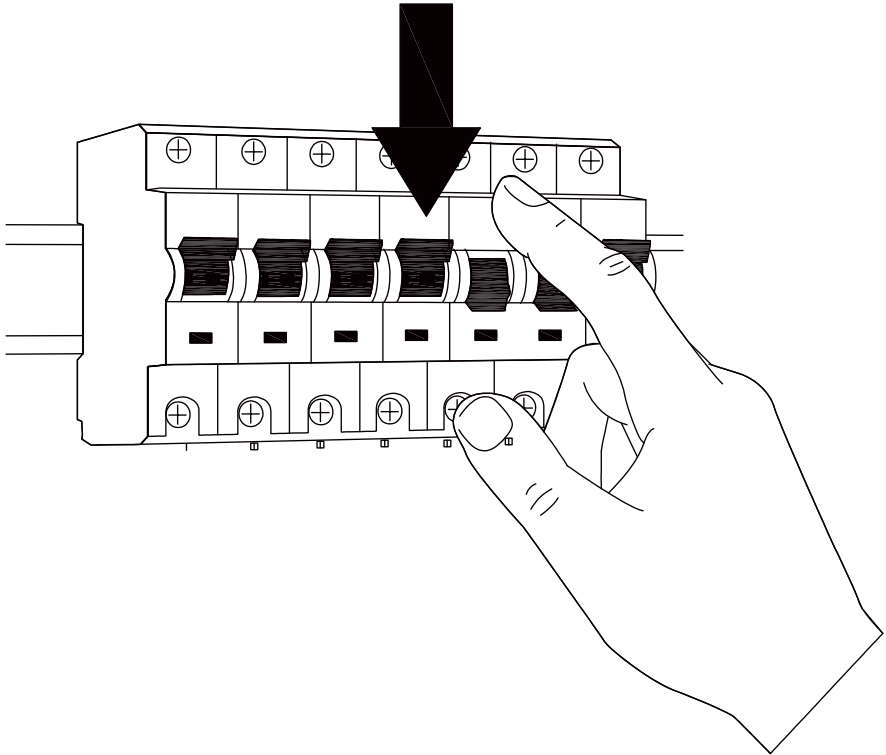

1

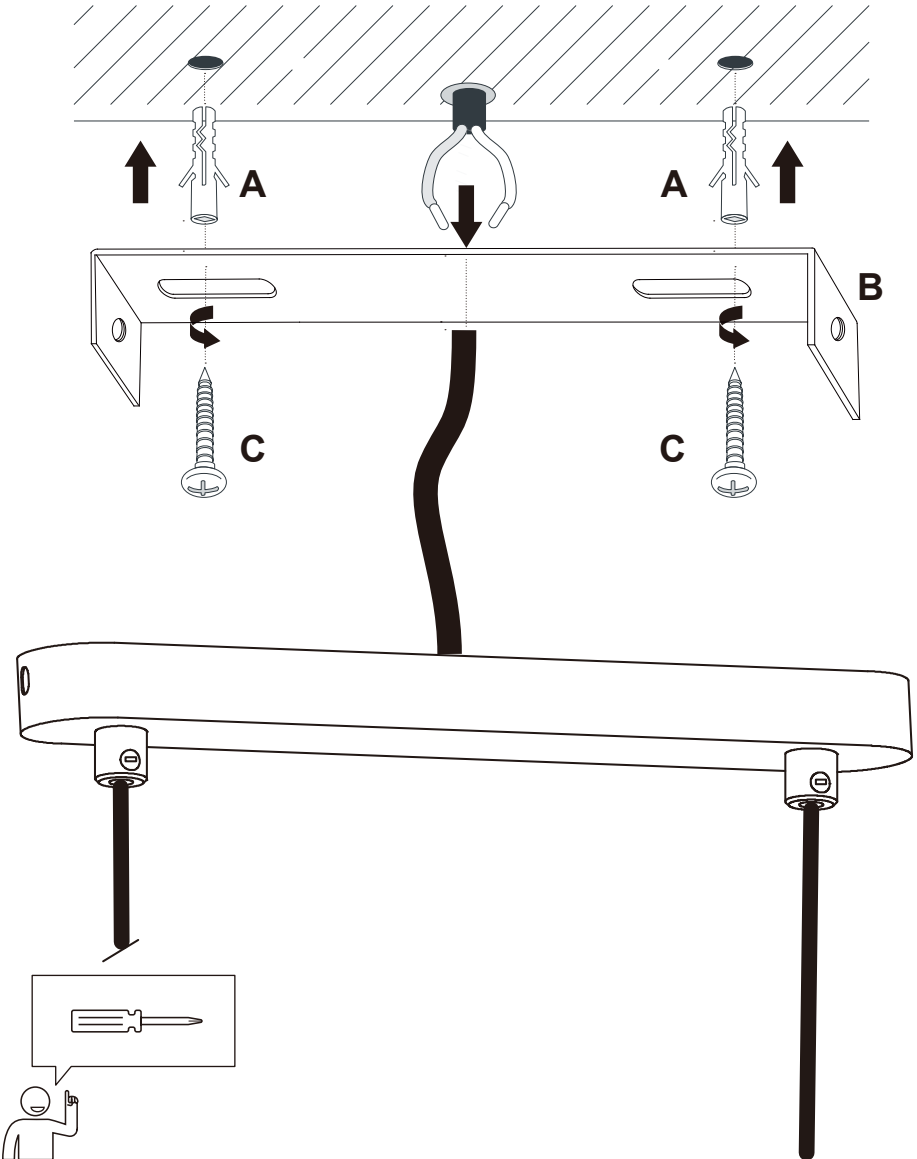

2

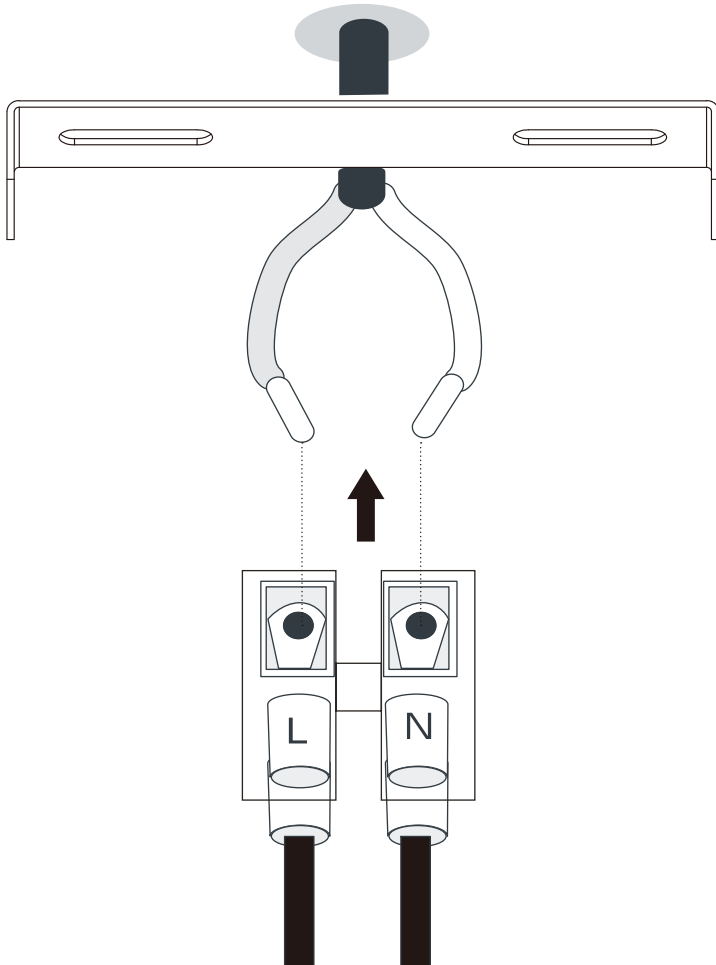

3

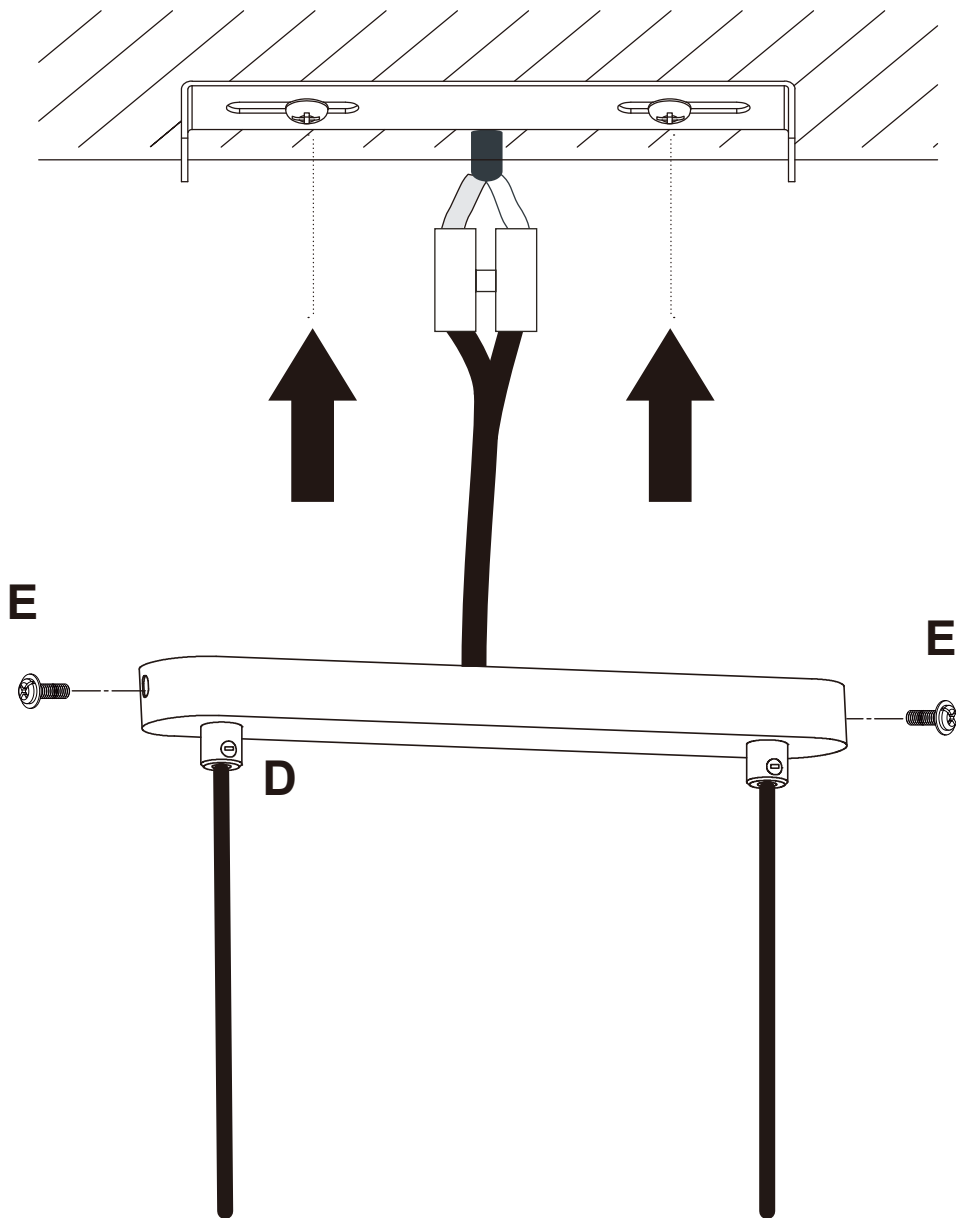

4

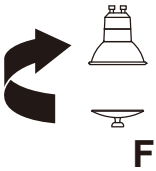
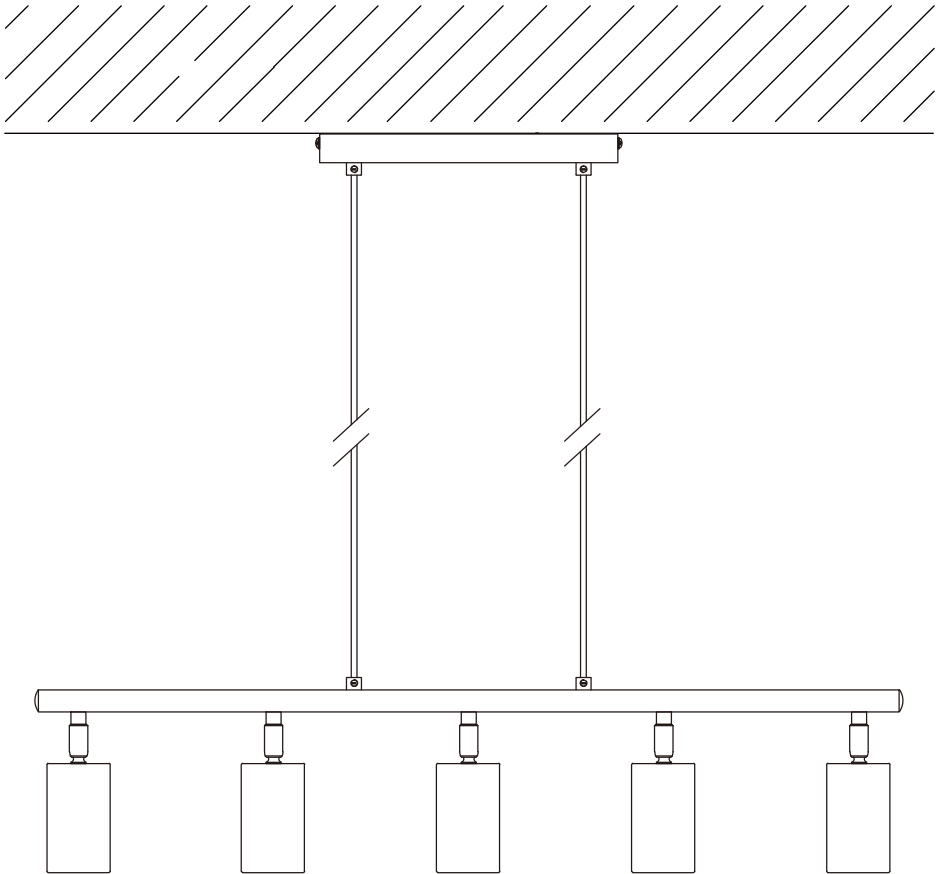

5

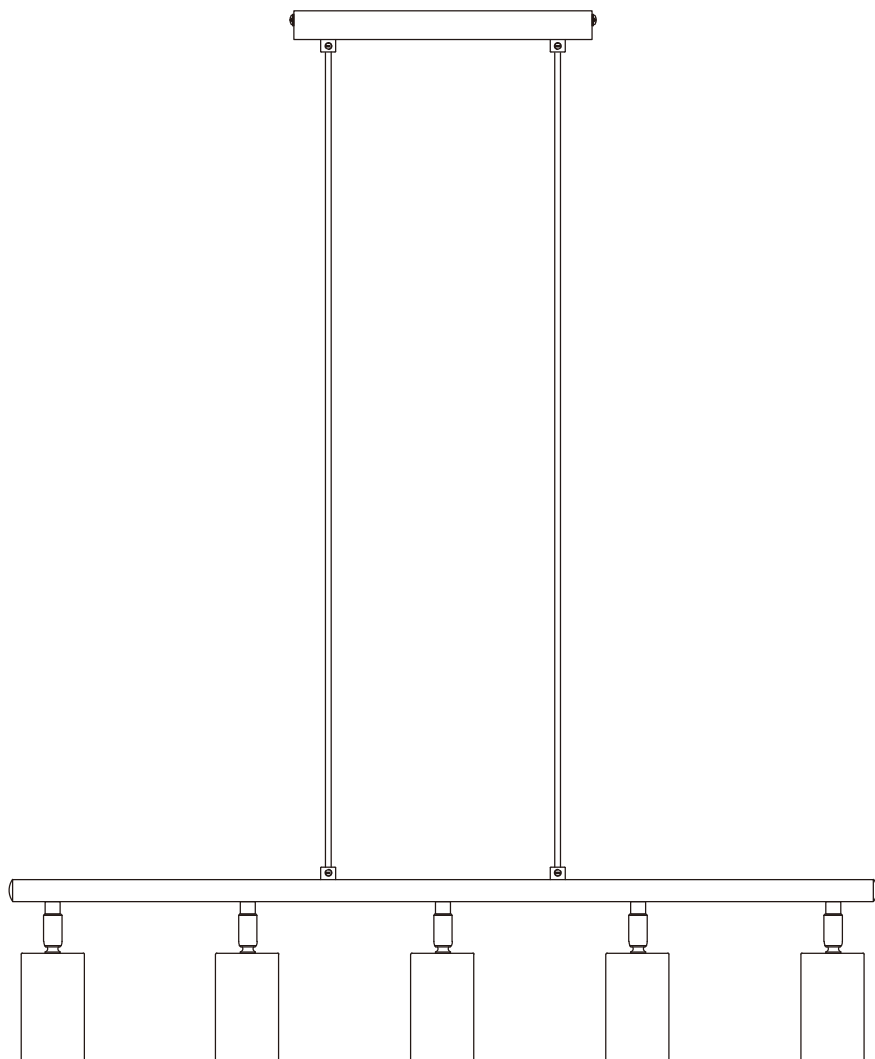



THAT'S ALL FOLKS!

Share your style!

#KaveHome

